

# Diamond-tool Type

## CAT'S EYE CEO Dimensional specification

### Dimensional drawing (mm)

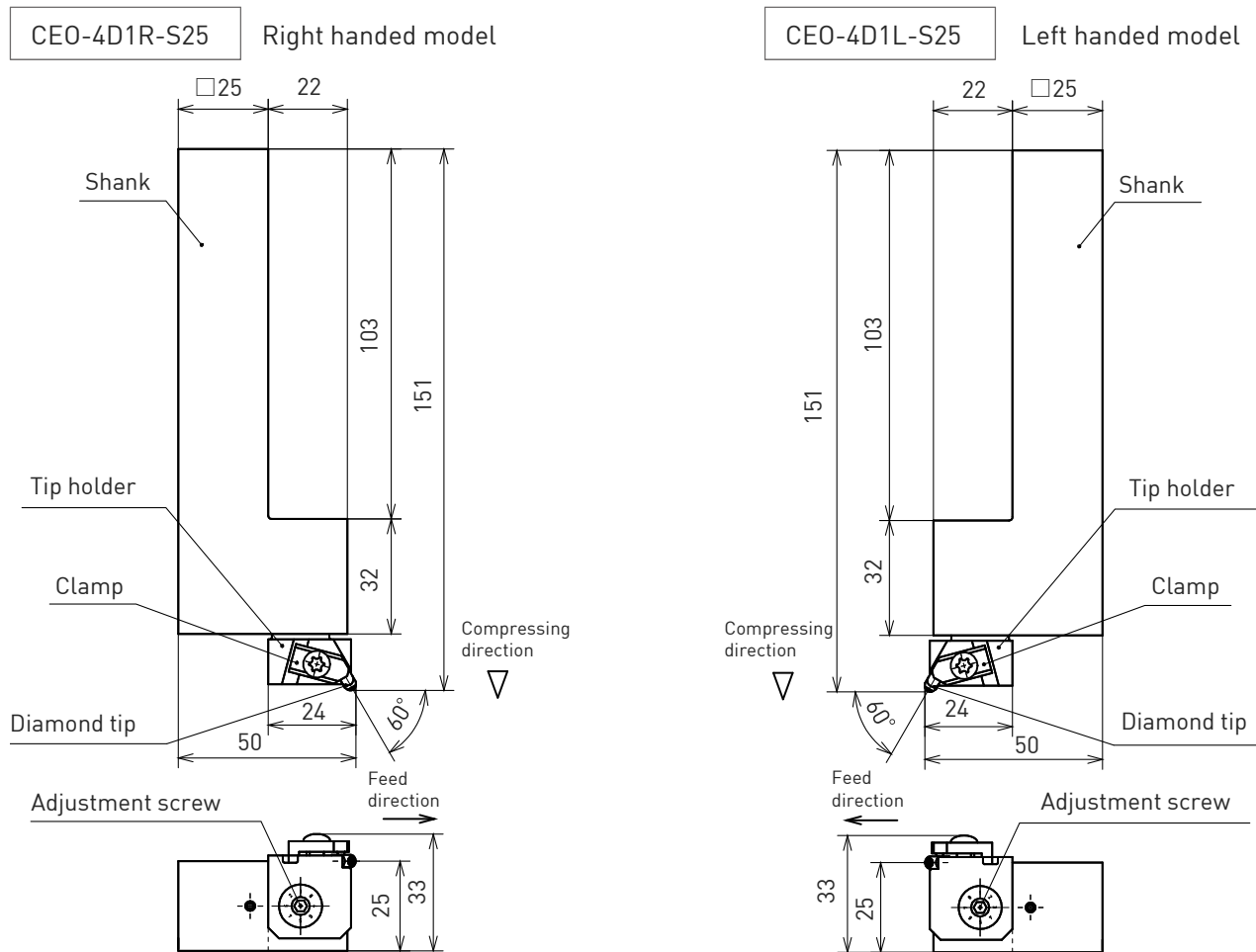

### Tool specification

Tool model	Burnishing part	Shank size(mm)	Orientation	Diamond tip model
CEO-4D1R-S25	Outer surface	□25	Right handed	DT4D1
CEO-4D1L-S25			Left handed	

### Burnishing condition (Ref. parameter)

Workpiece hardness (HRC)	Material	Peripheral speed (m/min)	Feed rate (mm/rev)	Pre-load (N)	Spring
45	Alloy steel	50 - 200	0.05	30 - 50	Spring(Blue)
60				150 - 200	Spring(Green)

\* Burnishing conditions are reference only, and do not guarantee that they will achieve the customers' required values.

\* Actual burnishing conditions vary depending on the material and conditions before burnishing, so these values should be used as a reference.

### Installation image on NC lathe

