

# Inquiry Sheet for "Tube Expanders"

to : Sugino Machine Ltd. International Div. Fax +81-3-5201-5978

INQ. No.	Date
Company Name	
Name	Title or Position
Address	
Phone	Fax
E-mail Address	

● Please attach the drawing of the workpiece.

Dimensions (mm)

1 Tube Size	OD	X	t
2 Tube Material			
3 Tube Sheet Thickness	T1	T2	
4 Tube Sheet Material			
5 Tube Sheet Hole Dia	H	Tolerance	
6 No. of Tubes to be Expanded			
7 Expansion Length	A1	A2	
8 Length of Tube Projection	E		
9 Hole Pitch & Arrangement	P1	P2	
	P3	P4	$\alpha^\circ$
10 Use of Lubrication Oil		Use	No use
11 Distance between Expansion	C	F	
12 Flare Angle	$\theta^\circ$		
13 Length of Straight Tube Part	S		
14 Curve Radius	R		

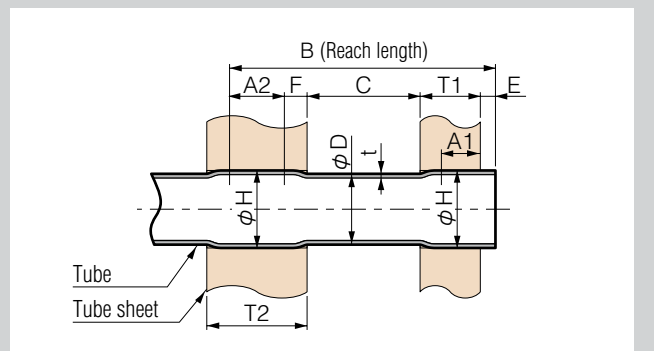
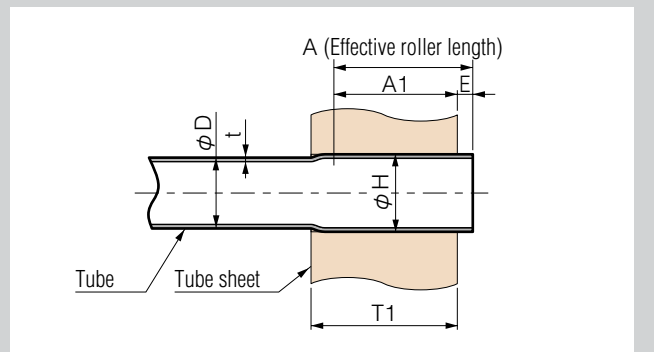
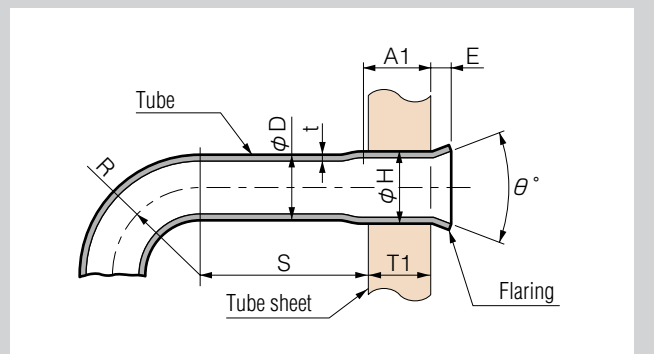
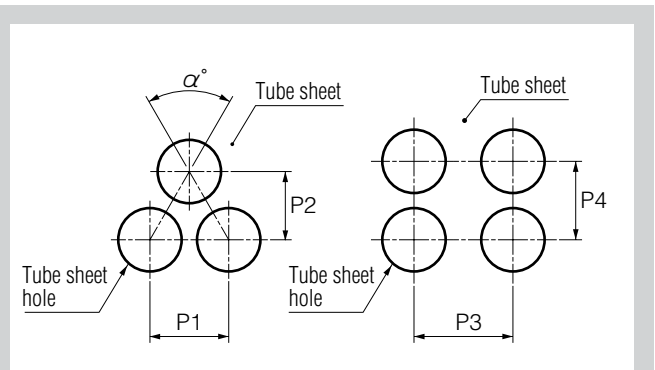

Sketch of expanding area

Remarks