

# Inquiry Sheet for "Superrolls"

to : Sugino Machine Ltd. International Div. Fax +81-3-5201-5978

INQ. No.	Date
Company Name	
Name	Title or Position
Address	
Phone	Fax
E-mail Address	

● Please attach the drawing of the workpiece.

Dimensions (mm)

1 Workpiece	
2 Material	
3 Hardness	
4 Shape of Burnishing Area (Please Mark)	① ② ③ ④ ⑤ ⑥ Others
5 Burnishing Dia. $\phi D1$	Before $\phi$ Tolerance: After $\phi$ Tolerance:
6 Dia. $\phi D2$	$\phi$ Tolerance:
7 Burnishing Length L	Tolerance:
8 Interference H	Tolerance:
9 Radius R	
10 Angularity $\alpha^\circ$	Tolerance :
11 Shank Size (Please Mark)	<input type="checkbox"/> MT Shank (Standard) <input type="checkbox"/> Straight Shank ( $\phi$ x L) <input type="checkbox"/> Others ( )
12 Limit of Tool Length (not including shank length)	
13 Main Purpose of Burnishing	<input type="checkbox"/> Improvement of surface roughness <input type="checkbox"/> Increase of surface hardness <input type="checkbox"/> Sizing <input type="checkbox"/> Others ( )
14 Surface Roughness	Before After ( Ry, Rz, Ra, Rms etc. )
15 Hardness	Before After ( HRC, HV, HB,etc. )

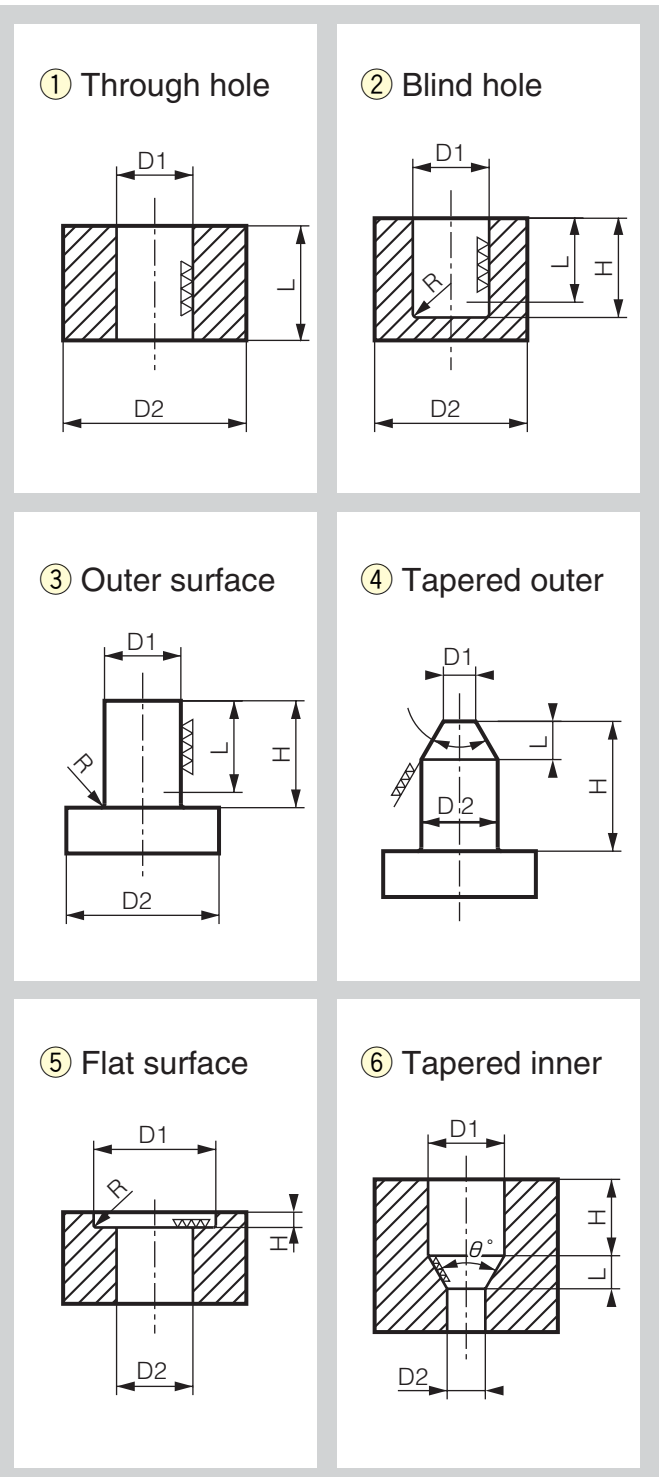

If you need the drawing of the tool, please mark.

- Reference drawing  
 Approval drawing

Remarks: